

# Power over Ethernet technology for industrial Ethernet networks

## Introduction

Ethernet networking has grown beyond office and home usage to become a very successful protocol suite used in many industrial networks. Industrial Ethernet's accomplishments can be attributed to its heritage in the commercial marketplace where most innovations and the evolution of the protocol suite took place; Power Over Ethernet (PoE) technology is no exception.

PoE was developed soon after offices began to adopt Voice over IP (VoIP) phone systems, VoIP phone systems allow offices to integrate their data and voice networks together and reduce calling costs, but early incarnations of VoIP phone hardware had the disadvantage of requiring a power supply for each headset - compared to traditional analogue phones which are commonly supplied with power and signal via the telephone wire. This motivated the development of a similar system for VoIP phones which have an Ethernet connection, and PoE was born!

Using PoE as a technology for powering end devices other than VoIP phones was an obvious step; the technology has quickly been adopted for many other applications such as remote wireless access points, IP based cameras and devices that are commonly found in industrial Ethernet network deployments.

## Basic principle of PoE

Power over Ethernet is a technology which enables electrical power to pass over Ethernet cabling at distances up to 100m, it is designed to provide end devices with sufficient power to operate with no need for a local power source. This technology complements standard Ethernet communication; it does not effect the transmission of data throughout a network.

A PoE system comprises of a minimum of four pieces of equipment:

1. Power Sourcing Equipment (PSE)  
A PSE is a device which supplies power to the rest of the system. It will draw power from its own conventional power source and provide power to the rest of the PoE system.
2. Powered Device (PD)  
A PD is a device which receives power from the PSE device. It does not require its own conventional power source.
3. Ethernet cable  
The Ethernet cable is the power and data transmission medium of a PoE system. It is used to provide the link between two devices enabling bi-directional communication and uni-directional supply of power.

## 4. Power Supply

There must be a power source from which the PSE draws power. Typically a PoE system is powered by a nominal 48VDC power source.

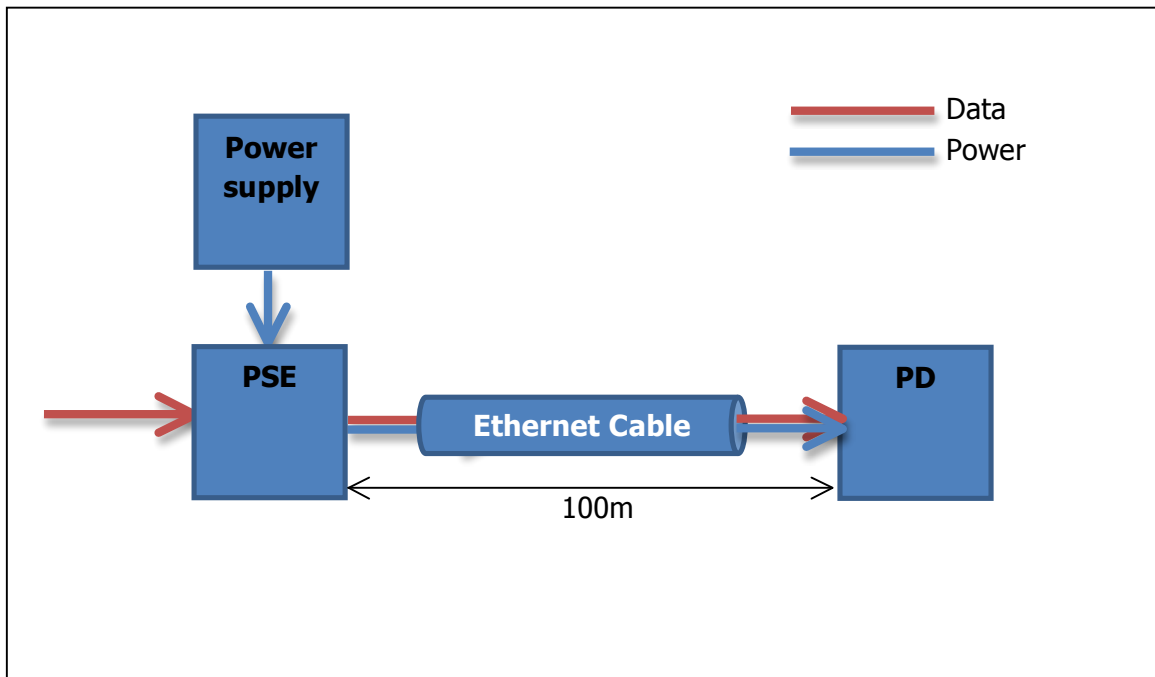

Figure 1: The basic principles of a PoE system.

## Benefits of PoE

The benefits of PoE are numerous; the ability to transmit data and power over Ethernet cabling at significant distances creates many possibilities for network designers:

**Efficient Network Design** With a PoE system, there is no longer a requirement for AC outlets and/or power supplies to be positioned in close proximity to the PD. With the shackles of power availability removed, the optimum placement of end devices can be considered.

**Simple low cost installations** The amount of equipment required for installations can be greatly reduced. End devices no longer need power supplies, extensive power cabling or AC outlets. Reducing the equipment required also reduces the installation time and complexity and ultimately, removes many potential points of failure in a system.

**Flexibility** The reduction of equipment required allows for the flexible deployment of networks; end devices can be relocated easily and temporary installs require much less time to implement.

**Central power management** In a PoE system you can distribute power and data in many different ways. One possibility is to distribute power and data from a central location in a star topology, this allows for central power management which can be backed up by a redundant power supply such as a uninterruptible power supply (UPS). In industrial networks, mesh or ring topologies are typically adopted; these use managed switches to provide efficient traffic management. Many managed switches on the market today that support PoE can be used

to remotely manage the power supplied to end devices, resetting the power if an end device is not responding, or time scheduling the power so that energy can be saved when the functionality of the end device is not required.

## The standardisation of PoE

The standardisation of PoE technology was a very important step forward as it guaranteed interoperability between different manufacturers equipment; with an international standard in place consumers could purchase compliant PSE, PD and Ethernet cabling from multiple vendors and still integrate a successful PoE system. The professional association responsible for the standardisation of PoE is the Institute of Electrical and Electronics Engineers (IEEE). The two current standards are as follows:

**IEEE 802.3af-2003** commonly known as *PoE*, this standard facilitates the supply of up to 15.4W of DC power.

**IEEE 802.3at-2009** commonly known as *PoE+*, this standard facilitates the supply of up to 34.2W of DC power.

### IEEE 802.3af-2003 (PoE)

IEEE 802.3af-2003 was the first PoE standard to be introduced; it enabled the provision of data and power to be sent over Cat 3 cable (or higher specifications of Ethernet cable).

As the latest standard (IEEE 802.3at) is based on the technology outlined by IEEE 802.3af, we must first consider the operation of IEEE 802.3af and then discuss the evolution to IEEE802.3at (see section **IEEE 802.3at-2009 (PoE+)**.)

## PD detection and classification

IEEE 802.3af PSE devices have a test mechanism which is designed to detect when a PD device is connected to a system and classify the amount of power required for that particular end device, it also serves as a safety mechanism, ensuring that non IEEE 802.3af end devices are not supplied power which can cause damage.

To determine whether an end device is connected to a PSE a method called *resistive power discovery* is used, a voltage is applied periodically so that the resistance of the end device can be detected, this resistance check will confirm if a IEEE 802.3af PD is connected or not. Upon detection of a compliant end device, the PSE will perform another resistance test in order to classify the amount of power that is required for that particular PD.

Class	Power supplied by PSE (Watt)	Class description
1	4.0	Very Low power
2	7.0	Low power
3	15.4	Mid power

Table 1. IEEE 802.3af-2003 power classification.

## Power feeding

There are two different ways in which power can be fed into a PoE system: Alternative A (sometimes referred to as Endspan or mode A) and Alternative B (sometimes referred to as Midsapn or Mode B). Each uses a different cable power technique to “inject” the power at the PSE end of the system, Alternative A uses a technique called phantom feeding and Alternative B uses a technique called spare pair feeding. The technique used depends entirely on the PSE utilised in the system, please note that all IEE 802.3af compliant PD will support either of these methods.

Phantom feeding provides power to the PD via the same Ethernet cable conductors as data. When using Cat 5 cable in a PoE system, pin 2/4 and 3/6 are used for power and data. The PSE superimposes power onto these conductors via the centre tap of internal signal coupling transformers. In the powered device (PD) the power is derived from these lines using the reverse technique.

Spare pair feeding provides power to the PD via the spare wire pairs in an Ethernet cable. When using Cat 5 cable in a PoE system, pins 4/5 and 7/8 are used for power and the conventional carry data as standard.

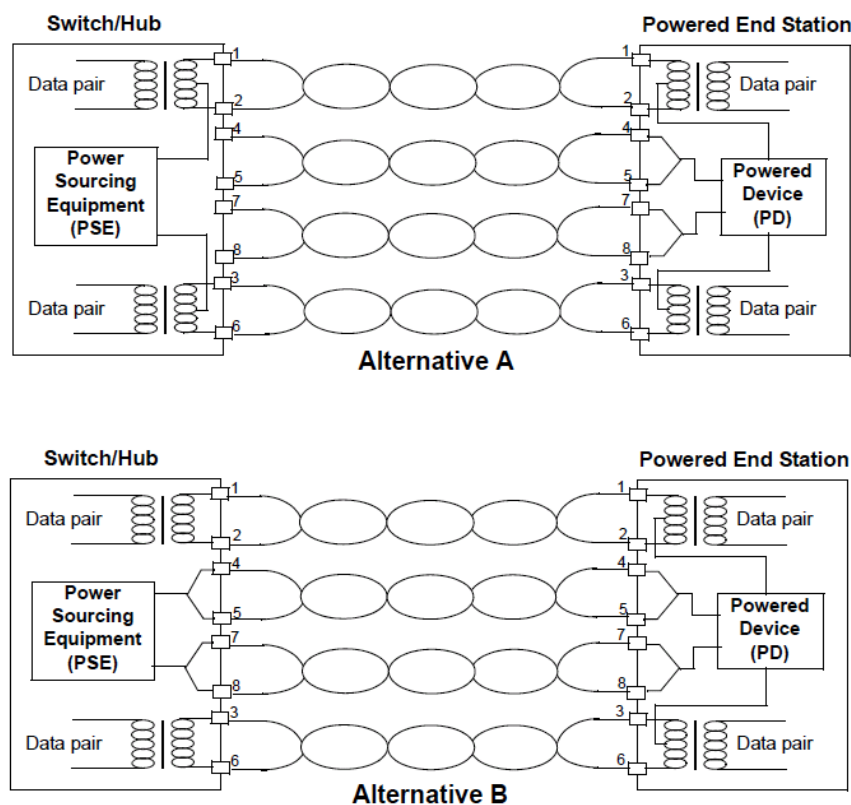

Figure 2. PoE Power feeding techniques.

## IEEE 802.3at-2009 (PoE+)

IEEE 802.3at-2009 Power Over Ethernet Plus (PoE+) is a gradual improvement of the IEEE 802.3af-2003 standard. As end device technology has evolved, so has the requirement for more power. For example, Wi-Fi access points are now supporting the latest power hungry 802.11n protocol, IP cameras now feature pan, tilt and zoom functionality (PTZ), some are

heated for outdoor installations and VoIP phones now support video, all of these products require more power to operate and hence PoE+ was developed to accommodate market demands.

PoE+ can supply 34.2W of power at the PSE, the maximum power available at the PD is 25.5W due to losses in a PoE+ system. Power feeding is achieved by using all 4 pairs of an Ethernet cable compared to two pairs used by the older standard, and hence deliver twice the power. It is backwardly compatible with IEEE 802.3af devices, the PSE will simply classify the PD (using the resistive power discovery method) and supply the appropriate amount of power to avoid damaging the PD.

Class	Power supplied by PSE (Watt)	Class description
1	4.0	Very Low power
2	7.0	Low power
3	15.4	Mid power
4	34.2	High power

Table 2. IEEE 802.3at-2009 power classification.

## PoE and PoE+ Comparison

Property	IEEE 802.3af	IEEE 802.3at Type 2
Power available at PD	12.95 W	25.50 W
Maximum power delivered by PSE	15.40 W	34.20 W
Voltage range (at PSE)	44.0–57.0 V	50.0–57.0 V
Voltage range (at PD)	37.0–57.0 V	42.5–57.0 V
Maximum current	350 mA	600 mA
Power management	Three power class levels	Four power class levels
Supported cabling	Category 3 and Category 5	Category 5 and above
Supported modes	Alternative A and B	Alternative A and B

Table 3. PoE and PoE+ comparison

## Products and applications

There is a growing demand for Industrial grade PoE equipment in many different industry sectors such as factory automation, Intelligent Traffic Control Systems (ITS), Security automation, Transport and Building management systems (BMS). Networks in these industries need to utilise rugged hardware to withstand operation in environments that are un-controlled, they need to be reliable to ensure mission critical operations are always functional and available.

There is a massive range of PoE equipment available from switches, injectors/splitters to media converters and wireless access points. Below are some examples:

## Managed/Unmanaged switches

Managed switches provide advanced network features and remote management capabilities; they are extremely useful when combined with PoE because the PoE power budget can be managed from a central location, typically via a website based graphical user interface (GUI).

Unmanaged switches are completely plug-and-play, they have no configuration interface or options. Their relative simplicity means that they are cost effective devices and hence, extremely low cost networks can be assembled.



- Classified as Power Sourcing Equipment
- IEEE 802.3at and IEEE 802.3af
- Connect many Powered Devices with a compact switch
- Rack/DIN-Rail/Wall/Panel mounting
- Fan-less, rugged design
- Redundant power inputs
- Fast Ethernet and Gigabit network speeds

## Media Converters

Media converters are used to transmit Ethernet data over long distances by converting the Ethernet transmission medium from electrical signal over copper wire to a light signal over Fibre optic cable. Commonly, media converters are used to extend the reach of a conventional copper based network to connect end devices which are placed in remote locations. PoE functionality is extremely useful in such applications because you can run power over the last 100m of the cable run to the end device.



- Classified as Power Sourcing Equipment or Power Devices
- IEEE 802.3at and IEEE 802.3af
- Cost effective long distance networks
- Achieve distances of up to 120km
- Immune to Electrical interference
- Single-mode, multi-mode and single-strand fibre optics
- Fan-less, rugged design

## Wireless Access Points and bridges

Wireless Access Points and bridges allow for wireless local area Ethernet network communication. They can be deployed to replace the need for cables in a point-to-point or point-to-multi-point network or provide mobile communication to end device wireless clients. Careful planning is required to ensure that wireless access point or bridges are positioned in the optimum location for maximum wireless link reliability, PoE is essential for mounting such equipment in hard to reach areas.



- Classified as Powered Devices
- IEEE 802.3at and IEEE 802.3af
- Robust and redundant mobile communication
- Industrial or outdoor rated enclosures
- 2.4GHz and 5GHz support

## Splitters and Injectors

Splitters are commonly used to divide the data and power from an existing PoE cable run so that the power can be redirected into the end device using more conventional means, such as a DC cable. They act as an intermediary device between a compliant PSE and a non-compliant PD.

Injectors are used to feed power into a non-PoE cable run, combine that power with an Ethernet data input and create a PoE output. They are ideal for adding PoE to an Ethernet network when an existing PD is available, but no PSE.



- IEEE 802.3at and IEEE 802.3af
- Fast Ethernet and Gigabit network speeds
- Rugged design
- DIN-rail/wall/panel mount

## Conclusion

PoE has become an extremely useful technology for industrial applications. Today its predominant market driving force is the requirement for connecting IP cameras and Wireless access points, however, more and more end devices are appearing in the market place which take advantage of PoE, such as sensors, detectors, security access devices, displays and human machine interfaces (HMI). PoE technology will continue to evolve as end devices require more and more power for operation, already there are proprietary Power over Ethernet systems available which will supply as much as 60W, currently such technologies are not standardised and are not interoperable, which can potentially harm non-compatible hardware, but the precedent has been set for a high power version of the standard to be developed.